

Frese per spigolare per macchine bordatrici

Milling cutters for chamfer on edge-banding machines

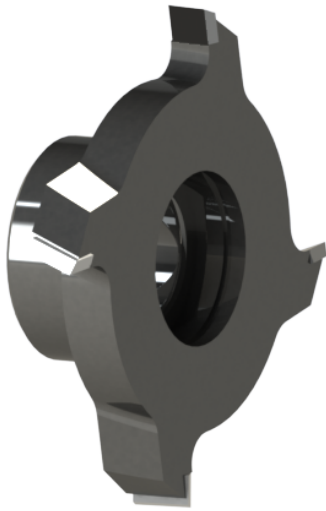

BIESSE

ØD	S	S1	Z	Mod.	Foro	Codice
70	8	22	4	A	20+2CH	FS01.70.8.4.20.R/L
70	8	22	6	A	20+2CH	FS01.70.8.6.20.R/L
80	8	22	4	A	20+2CH	FS01.80.8.4.20.R/L
80	8	22	6	A	20+2CH	FS01.80.8.6.20.R/L

SCM

48	8	12.4	4	A	16+2CH	FS01.48.8.4.16.R/L
----	---	------	---	---	--------	---------------------------

HOMAG e IMA

70	8	22	4	B	HSK25	FS01.70.8.4.25.R/L
70	8	22	6	B	HSK25	FS01.70.8.6.25.R/L
70	8	22	4	A	HSK25	FS01.80.8.4.25.R/L
80	8	22	6	A	HSK25	FS01.80.8.6.25.R/L

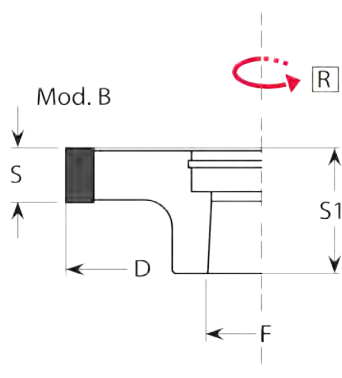
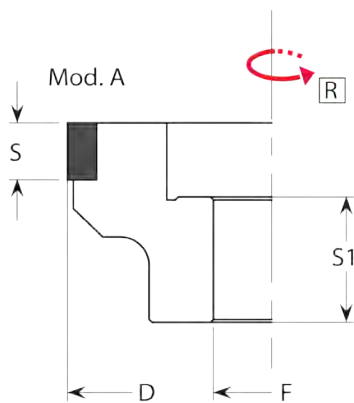

Caratteristiche

Frese per refilare l'eccedenza del laminato plastico su macchine bordatrici. Altezza diamante 2.7mm.

Characteristics

Cutters for draw out the plastic leaf on edge-banding machines. Diamond height 2.7mm.